

Pump Model CPS 400-300-435

Speed 1450rpm

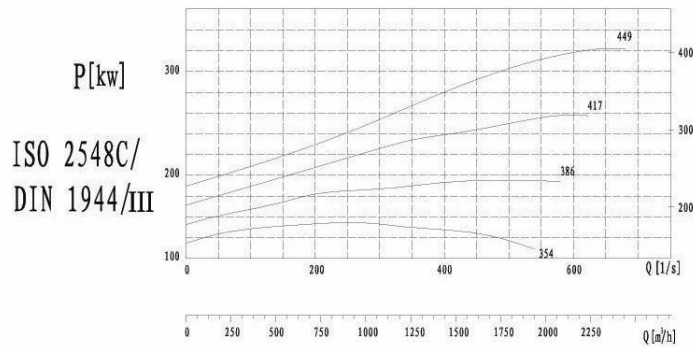

ISO 2548C/
DIN 1944/II

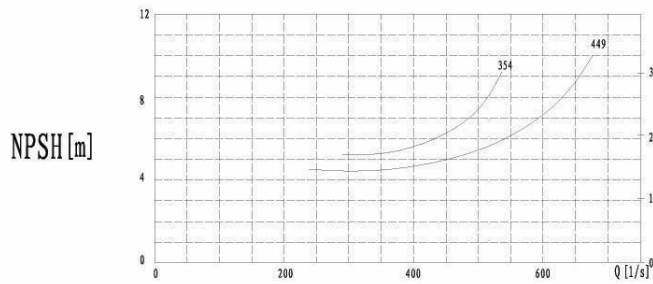
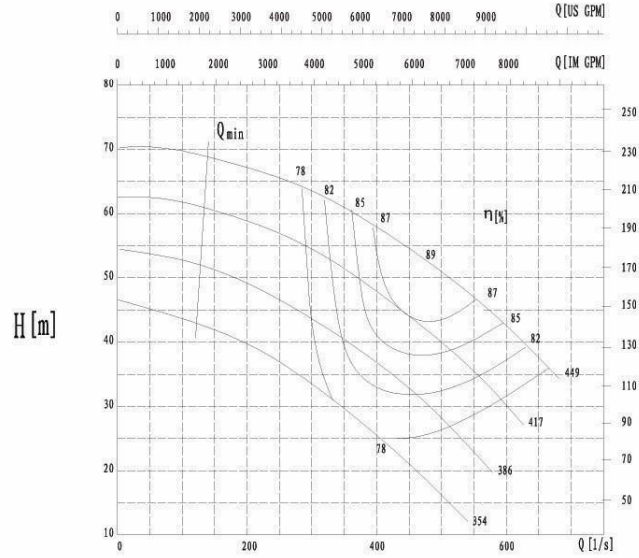
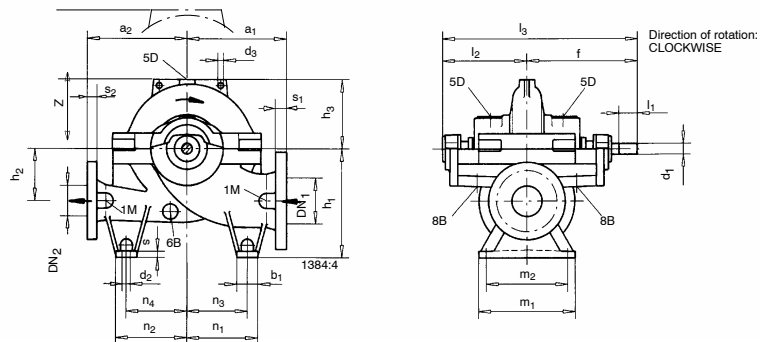

Pump Size	FLANGE DIMENSIONS				PUMP DIMENSIONS									
	DN1	DN2	s1	s2	a1	a2	d3	f	h1	h2	h3	l2	l3	z
CPS 400-300-435	400	300	38.1	33.4	650	550	24.5	730	670	350	365	515	1245	730
	FOOT DIMENSIONS									SHAFT		PUMP WEIGHT		
	b1	d2	m1	m2	n1	n2	n3	n4	s	d1	L1	(kg)		
100	22	600	520	400	400	350	350	26	75	160	905			